

***Risk Assessment
Using the TRAM safety system to
prevent falls from road tankers
(New South Wales)***

***Prepared by
Grant Tracy
Director of Occupational Health & Safety
Standfast Corporation***

September 2004

Disclaimer and Copyright Notice

1. The purpose of this Risk Assessment is to provide guidance on the issue of road tanker height safety and the appropriate New South Wales legislation and regulation. It is not exhaustive in its coverage of rights or obligations nor is it legal advice.
2. This Risk Assessment is based on the author's interpretation of the relevant legislation and regulation in respect of height safety in road tankers and has no legal status or legal effect whatsoever. Any reference to systems to prevent falls from road tankers is for guidance only. Readers of this Risk Assessment should seek appropriate guidance from WorkCover New South Wales as well as obtain appropriate legal advice in respect of the application of the legislation and regulation in respect of those safety systems.
3. This Risk Assessment may be affected by changes to legislation or regulation. Standfast Enterprises Pty Ltd and Standfast Corporation Pty Ltd (Standfast) accepts no responsibility for the accuracy, completeness or currency of the material included in this Risk Assessment.
4. Users of the Risk Assessment are encouraged to obtain professional advice on the relevant legislation and regulation and to exercise their own skill and care in relation to any material contained in this Risk Assessment.
5. Standfast disclaims any and all liability or responsibility for any loss or damages arising out any use, or reliance on, this Risk Assessment.
6. This Risk Assessment is copyright. You may use and reproduce this material in an unaltered form only for your personal non-commercial use or non-commercial use within your organisation. Apart from any use permitted under the *Copyright Act 1968*, all other rights are reserved. Requests for other types of use should be directed to Standfast.

About the author

Grant Tracy is the Director of Occupational Health and Safety at Standfast Enterprises. He holds a Master of Science and Technology in Occupational Health and Safety from the University of New South Wales where he was awarded a University Prize in Ergonomics. He also holds a Bachelor of Physiotherapy and Bachelor of Human Movement Studies majoring in Exercise Physiology and Biomechanics from the University of Queensland. He is a skilled and experienced professional with over 15 years experience in occupational health and safety.

Table of Contents

1. Introduction 5

2. Method..... 7

3. Results..... 8

 Hazard..... 8

 Risk (Fine Method)..... 8

 Controls 9

 Residual Risk / Effectiveness of Control..... 15

4. Discussion 16

 The Law..... 16

 Risk and Controls 17

5. Conclusion 18

References 19

Appendix I Falls From Road Tankers Fall Event Histories..... 20

1. Introduction

Standfast Corporation Pty Ltd (Standfast) conducted a Risk Assessment to assess the use of the TRAM (Total Restraint Access Module) to prevent falls from road tankers.

The TRAM is designed to provide a safe means of accessing the top of tankers from the ladder and working on top of road tankers. The TRAM safety system is designed so that the user is firmly attached to the unit at all times and cannot fall. The safety system includes a mechanical component that slides along a rail fixed to the tanker and a specially designed restraint belt attached by two lanyards. The TRAM provides a handhold that moves with the operator (vertically and horizontally) and is also a moveable anchor point for the restraint belt.

The TRAM has been developed in response to the continuing problem of workers being killed or seriously injured as a result of falls from road tankers. Product development of the TRAM sought input from the road tanker transport industry, including manufacturers, owners and drivers, as well from occupational health and safety (OHS) professionals and engineers. Hazardous Operability Studies were used to analyse the risk of falling from road tankers and devise a safe working system. The innovative engineering of the TRAM is the result of this effort and represents both new technology and a change in paradigm for road tanker safety. It must be demonstrated that the TRAM is a suitable and effective measure to prevent falls from road tankers for the TRAM to be accepted within the New South Wales (NSW) regulatory framework. This report will assess the effectiveness of the TRAM to control the risk of falling from road tankers.

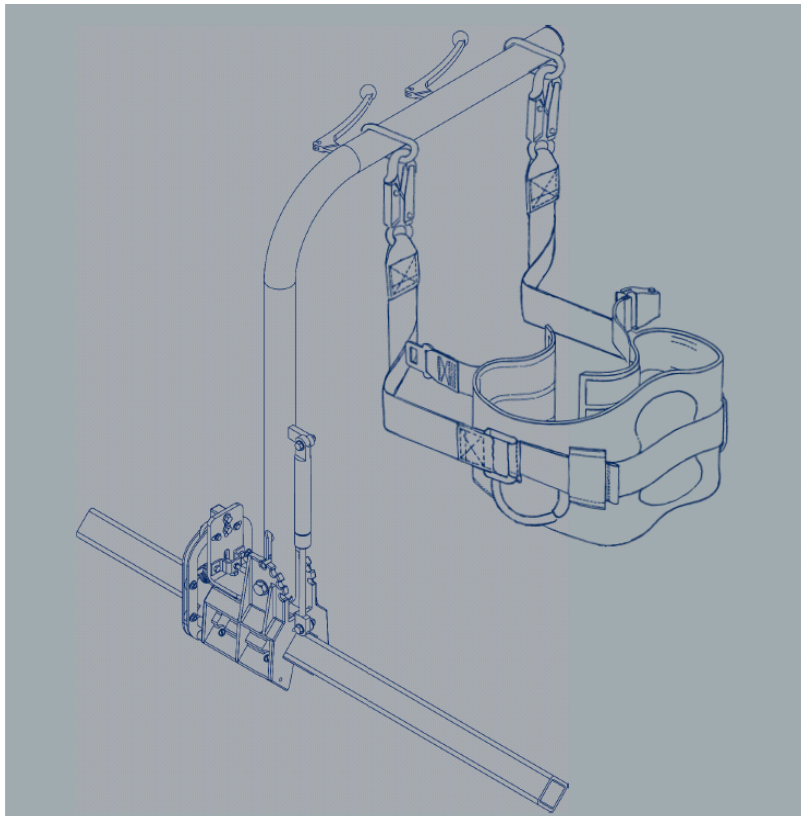

Drawing 1: The TRAM (Total Restraint Access Module)

Grant Tracy, Director of Occupational Health and Safety for Standfast conducted the Risk Assessment and prepared this report. The level of information collected about road tanker height safety in the preparation of this report is uniquely comprehensive. The report will present the most recent review, including new findings and greater detail than previous discussions on this topic.

The Risk Assessment was conducted in accordance with the health and safety system in NSW, as described in and regulated by the following:

- NSW Occupational Health and Safety Act 2000,
- NSW Occupational Health and Safety Regulation 2001
 - Part 4.3 Use of places of work
 - Division 6 Working at heights
 - Clause 56 Prevention of falls from heights – particular risk control measures
- AS/NZS4360 Risk Management,
- WorkCover NSW Health and Safety Code of Practice for Risk Assessment, and
- WorkCover NSW Health and Safety Guide: Risk Management at Work.

The Risk Assessment was undertaken to assess compliance with legislative and regulatory duties. In particular, the Risk Assessment was conducted with regard to the following:

- To meet the employer's obligation to identify foreseeable hazards, assess the risks of those hazards and eliminate the risks, or if not reasonably practicable to do so, then control the risks, and
- Drivers were consulted to enable them to contribute to the making of decisions affecting their health, safety and welfare at work.

2. Method

A hazard identification exercise was conducted as follows:

- the health and safety system of NSW was reviewed. This included a review of legislation, regulation, approved codes of practice and guidance material produced by the regulatory authority, the WorkCover NSW,
- a review of literature relating to falls and road tanker height safety was conducted,
- safety statistics, as collated and published by regulatory authorities were analysed,
- a search for fall event histories of falls from road tankers was performed. Web searching provided a number of fall from road tanker accident reports and investigations. The fall event histories have been collated and reported in the document *Falls From Road Tankers Fall Event Histories* and is attached in Appendix I,
- an extensive series of meetings through out Australia, Europe, Great Britain, the USA, Canada, Japan and New Zealand with regulatory authorities, industry groups, tanker manufacturers, fleet owners, drivers and OHS representatives thereby ensuring a comprehensive understanding of road tanker height safety was developed,
- various fall protection systems for use on top of tankers were reviewed. This included using the systems on tankers in operation. Meetings were held with designers and manufacturers of handrail systems and promotional and other material was reviewed,
- all aspects of TRAM design, manufacture and testing were reviewed, and
- the TRAM was tested in operation.

Key Issues:

- a “What might go wrong?” approach was used,
- hazards were identified,
- risks were assessed using the Fine Method, that is consequence, exposure and likelihood factors were determined and a level of risk calculated,
- the TRAM was applied as a control,
- the effectiveness of the control was assessed,
- OHS principles such as the hierarchy of controls are used to assess the risk control. Published research, statistics and case studies were used as evidence to support assessment of controls, and
- residual risk was calculated.

The results of the Risk Assessment, detailing the assessment of risk, discussion of controls and residual risk is provided in Section 3.

3. Results

Hazard

Working at height

Risk (Fine Method)

Fall from height

Consequence (most likely)

- Very serious / permanent disability / 25
- Fall event histories collected for this Risk Assessment included some cases where drivers have lived with serious injuries after falling from tankers, such as paraplegia whilst other drivers have died.

Exposure

- Frequently / approximately once daily / 6
- The requirement for access to the tanker top varies across industry. There is an effort to reduce the need to access the tanker top or access at a fixed location with full gantry. However, it was discovered through extensive industry meetings that access to the tanker top (where a fixed gantry is not available) cannot be eliminated altogether. (Access to the tanker at a fixed location where a full gantry is used has not been included as an exposure for this risk assessment.)

Likelihood

- Almost certain / Is the most likely outcome / 10
- The likelihood of very serious injury / permanent disability (or worse) occurring as a result of a fall from a tanker is almost certain. As some falls have resulted in fatality, it is unlikely that the victim will escape with non-permanent injury. The biomechanics of the fall could be modelled to show that the resultant forces would be far greater than the failure load of soft tissue and bone.

Risk = Consequence x Exposure x Likelihood

- $25 \times 6 \times 10 = 1,500$
- >300 / Very high risk

Controls

Elimination / Substitution / Minimisation

- The TRAM should not preclude current efforts to eliminate or reduce the need for tanker top access. However, to eliminate the need for tanker top access does not seem possible and certainly has not been achieved to date. Therefore, the working at height hazard and fall from height risk must be treated with additional controls.

Engineering

- The use of bottom loading should reduce the need to access the tanker top, and therefore reduce frequency of exposure and the overall risk.
- ‘Diptronics’ allow the level of fuel in petroleum road tankers to be measured without needing to access the top of the tanker. This very costly engineering control may improve height safety and control the risk of fall in petroleum road tankers, but is not applicable to dry bulk powder tankers.
- Powered man lids have been proposed as a possible engineering control for tanker top height safety. There was no evidence found for the success of this approach through the current risk assessment project. There were some concerns expressed about the workability of such an approach, particularly with regard to maintenance.
- Loading and unloading road tankers at fixed locations with full gantry would provide a control to the risk of fall. However, the road tanker industry has not found it reasonably practicable to limit access to tanker tops to fixed locations with full gantry. For example, some loading and unloading locations do not provide a gantry. Drivers also occasionally need to check the lid seals en route as a defect could cause spillage or spoil the load.
- The TRAM utilises innovative engineering to provide a fall protection system that is specifically designed for road tankers.

An ideal system of mobility and restraint is achieved through the vertical movement of the hand-hold, which is also where the two 75cm lanyards are attached. For example, whilst standing and walking the anchor points are approximately at waist level. If the driver was kneeling, squatting or sitting to work, then the hand-hold and anchor points can be lowered to accommodate this change in posture.

The horizontal movement of the TRAM along the fixed rail ensures that the operator can move safely along the top of the tanker. Whilst walking along the top of the tanker the handhold provides support to the operator who must hold the unit and release a ‘dead mans brake’ to allow movement. The user, wearing the purpose-designed restraint belt attached by two lanyards, is firmly attached to the unit at all times and cannot fall. The system provides the operator with mobility and restraint.

Unfortunately the poor height safety record for road tanker safety is paired with an approach that has not included the use of personal fall protection. The obvious need for a shift in paradigm was the genesis for the revolutionary approach taken in the TRAM design.

A review of work-related fatalities involving falls in Australia found that more than 96% of victims were not using personal fall protection (NOHSC, 2000). It was found that all, or nearly all, of the deaths were preventable and the use of personal fall protection devices was recommended.

- **The TRAM controls the risk encountered when moving on to the tanker from the ladder, and off the tanker back on to the ladder.**

The movement of the hand-hold from its horizontal position (when the driver is on the ladder) to its vertical position (when the driver is standing on top of the tanker), has been termed a 'moving rung'. The 'moving rung' also ensures that the operator is facing inwards to the ladder as they move from the top of the tanker back on to the ladder. The TRAM provides a solid handhold that moves with the operator through the transition and is also a moveable anchor point for the restraint belt that is attached by two lanyards. The TRAM safety system is designed so that the user is firmly attached to the unit at all times and cannot fall. This is a revolutionary and unique engineering control to the risk of moving on to the tanker from the ladder, and off the tanker back on to the ladder.

Handrails and static line systems do not adequately control the risk of falling from road tankers, as the risk of moving on to the tanker from the ladder, and off the top of the tanker back on to the ladder is not controlled. Many of the falls from road tanker fall event histories show that there is a risk of falling at this transition.

The TRAM is the only safety system that controls the risk of falling when moving on to the top of the tanker from the ladder, and off the top of the tanker back on to the ladder.

Case Study

Last year, in the British Midlands in the UK, a dry bulk powder / cement carrier company that had handrails and walkways on top of its tankers, had a driver fall whilst accessing the top of the tanker. The driver fell from the top of the ladder and suffered serious spinal injuries.

Following the accident, the fleet managers could not warrant the use of handrails to control the risk of falls. Although the removal of the ladders from the tankers was considered, it was not practicable to eliminate access from the top of their dry powder / cement tankers. For example, a leaking hatch seal en route could spoil a load. If the driver returned unnecessarily to the load facility to access the top of the tanker from a fixed gantry to check a suspected leak, then costly delivery time penalties would be incurred. Drivers needed safe access to the top of tankers, away from fixed gantry locations.

- The TRAM has been ergonomically designed so that it can be raised and lowered so that it is at a suitable height for all users.

In comparison, handrail systems may not be safe for workers who are taller than average who are at risk of fall by pivoting over handrails. Anthropometric principals dictate that a single fixed height will not provide a safe barrier to all people from the range of shortest to tallest.

The problem of one fixed height handrail can be exacerbated by the relative position of the handrail and walkway. Because road tankers are cylindrical, it is often difficult to place the handrail and walkway in the appropriate positions. The top handrail may end up lower than expected because it is fixed lower on the curve of the tank and the same placement may mean that the handrail is too far out or away from the walkway. Each tanker is different, and the variability, particularly when retrofitting, may reduce the effectiveness of the handrail to control falls.

- The TRAM controls the risk of fall by restraining the user. Although the user can move along the top of the tanker, they are prevented from reaching a fall-risk position.

The provision of physical barriers must form a complete perimeter and surround any worker at height on all edges where there is a risk of fall. Unfortunately most handrail systems only provide a barrier on one side of the work area. It has already been discussed how there is a risk of fall at the point of access and egress but importantly more than half of the remaining edges of the work area remain unprotected. Work tasks on top of the tanker usually require the driver to move from one end of the tanker to the other, stopping to carry out specific tasks in the (top) middle where any tank openings are located. The driver is therefore exposed to risk of fall at the end of the tanker and along the unprotected side edge.

- The top of the tanker presents numerous trip hazards that can send a driver over or off the top of the tanker in any direction. The case study and testimonial below demonstrates how the TRAM 'saved' a driver.

Case Study and Testimonial

An independent road tanker operator in Victoria had installed a TRAM safety system on his vehicle. This experienced driver had been sceptical about the need to control the risk of falls from road tankers and had only installed the TRAM to comply with the new law, the Victorian Occupational Health and Safety (Prevention of Falls) Regulations 2003.

Recently, he was moving back along the top of his tanker when he tripped on an open hatch near the end of the vehicle. The TRAM prevented him from falling over the end of the tanker. The driver reported that the TRAM had saved him from serious injury or even death. He also noted that only the TRAM would have saved him as handrails would not have stopped him falling off the end of the tanker.

- The TRAM provides fall protection even when other hazards and risks exacerbate the risk of fall from height. For example, in a number of the case studies the driver was overcome by hydrogen sulphide, precipitating a fall from the tanker. There were also case studies of falls that were precipitated by physical hazards such as pressurised water and compressed air hoses or hatches on pressurised tanks.
- The TRAM may be the only control robust enough to keep a driver who has been injured or rendered unconscious from falling.
- The TRAM has been tested and approved to:
 - Australian/New Zealand Standard 1891 Industrial fall-arrest systems and devices
 - Part 4: Selection, use and maintenance.

The TRAM was categorised and tested as a 'total restraint' system, which is defined as not allowing the operator to reach a fall-risk position. A static load of 6kN was used in testing for the standard.

The TRAM has also been tested under dynamic conditions. Testing of the TRAM included dropping a 136kg-test dummy through a distance of 1.2m. The maximum arrest force recorded was 17.3kN. The TRAM remained intact and passed the test.

Australian Standards do not require guardrails or handrails to be designed to withstand loads of the same magnitude as personal fall protection systems. For example, the test load for guardrails (AS1657-1992) requires a test force of 550N or 330N/m, which is significantly less than the test load for a fall restraint anchor point (AS1891.4-2000) which is 6kN. There were widely held concerns about the effectiveness of the handrails from the tanker industry and even from the designers and manufacturers of handrails.

- The TRAM is suitably robust, sturdy and durable to meet the harsh mechanical forces that are encountered in Australian road transport. Road tankers may travel long distances over secondary roads en route to deliveries.

Feedback from fleet operators has been critical of the ongoing and costly maintenance and repairs needed by the handrail systems. The vibration and buffeting of handrails causes the movable parts of the system to loosen, which affects the stability of the system when erected.

The TRAM is comparatively compact and strong in its construction, whilst the TRAM rail is rigid and fixed to the tanker.

- The TRAM is made of high grade stainless steel which will not corrode and is resistant to many chemicals that are found throughout industry and transported by road tankers. For example, the stainless steel TRAM is ideal for use on vehicles working at aluminium smelters where there is atmospheric sodium hydroxide, which would prohibit safety systems that used aluminium parts in construction.

Behavioural

- Safety principles predict that it is better to eliminate, minimise or engineer out risks, than to rely on human behaviours. In fact, human behaviour and risk could be seen as cause and effect.

Humans can be expected to take risks, have accidents and underestimate the catastrophic. For example:

- a driver climbs onto his road tanker without fall protection even though he is parked outside of a load-out facility with fall protection (takes a risk),
 - the driver slips and falls to his death (has an accident), and
 - the driver could not have thought that his actions would result in falling to his death (underestimate the catastrophic).
- Some road tanker companies instruct their drivers to only access the top of tanker at fixed locations with full gantry. However most road tankers have ladders providing the opportunity to access the tanker top away from fixed locations with full gantry. Human behaviour principles would predict, and meetings with road tanker industry stakeholders confirm, that drivers will disobey instructions and continue to access their road tankers away from fixed locations with full gantry. The fall event histories show that drivers have been killed in falls when, in violation of instructions, they have accessed the top of their road tanker away from fixed locations with full gantry.
 - A subtler problem can be found in an analysis of handrails and human behaviour. The problem occurs because it is perceived that the handrails eliminate the risk of falling, but falls can occur on the ladder at access and egress. Also, handrail systems may not be safe for workers who are taller than average as they are at risk of fall by pivoting over handrails. Handrails reduce the perception of risk but do not adequately control the risk. The risk of fall is increased, as the behaviour is reflective of the perceived risk while the real risk is greater.
 - It is a benefit of the TRAM that its design and operation facilitates favourable behavioural responses to height safety. For example;
 - the operator must grasp the hand-hold to operate the brake and move along the top of the tanker. Reaching and holding for support is a 'natural' response to a perceived risk of a trip slip or fall, so the action required to operate the TRAM has facilitated a safe behaviour,
 - because the TRAM is attached to a fixed rail, the driver will always be guided to walk along the walk platform, which is to the side of the hatches, and devoid of trip hazards. So again, the design and operation of the TRAM has facilitated a safe behaviour, and
 - a worker may assess that the risk of fall is proportionate to the control measure. For example, if there was no control, then it might be assessed that there was no risk, but using a fall protection system with specially designed restraint belt suggests that there is a risk of falling. The TRAM design and operation will alert the driver to the height safety hazard and facilitate appropriate behavioural responses.

As we expect workers to take risks, have accidents and underestimate the chance of catastrophe, it is a benefit if the work environment can be designed to mitigate the influence of these behaviours.

- The TRAM requires competency based training to ensure that the system is operated correctly.

Training drivers to use the TRAM will educate drivers and increase awareness of the risk of falls from road tankers and provide the requisite skills to perform their work safely.

Training and instruction can help to change human behaviours through the education of workers about risks and show them how to perform their work safely.

The advantage of requiring competency-based training in a safety system is that the training is then the starting point. That is, the worker is trained and tested before they are allowed to start their work. The increased risk of death and injury on the first day of work or before experience is gained is well recognised. In a study into worker death by falls in the USA, 40% of the fall fatalities had been employed for six months or less (US Department of Health and Human Services, 2000). A requirement for competency-based training has the potential to prevent nearly half of all falls, as these falls occur because of a lack of skills and experience.

It is appropriate that all workers who work at height are trained in the associated hazards and risk of fall. This is particularly so for safety systems that require user interaction. We note that even though all handrail systems require operation to erect the barrier, there have not been any height safety training programmes provided by manufacturers of handrail systems found during the preparation of this report.

- The operator who has passed the TRAM competency-based training may provide instruction to a third party for limited and supervised access to the tanker top. For example, a service station worker who has not been trained to operate the TRAM may request access to the tanker top to measure the fuel in a tanker. The driver who will be qualified to use the TRAM will also be qualified to give a demonstration, instruct and supervise the service station worker. Simple verbal instructions such as “like this-do that”, as used in military training, are used to explain how to operate the TRAM safely. The inclusion of this competency raises the skills and knowledge of the operator and the opportunity to demonstrate, instruct and supervise will reinforce those skills and knowledge. In this way, the competency based training helps to develop a safe approach to height safety.
- Because the TRAM requires the worker to follow instructions to use the system safely, it can be argued that either a lack of competency or deliberate misuse can render the system unsafe. However, very little instruction or training is required to use the TRAM properly and once attached to the system it is nearly impossible to fall, even if, with reckless disregard to their safety, a worker tried to jump off the vehicle.

Although the main principle of the NSW Occupational Health and Safety Act 2000 is that those who create risk from work activity are responsible for the protection of workers, there is also a general duty for employees to co-operate with their employers and take care. The TRAM requires workers to understand and comply with very simple instructions and actions. Failure to do so would demonstrate disregard to their own welfare and be in breach of their general duty as imposed under the Act.

Residual Risk / Effectiveness of Control

- The discussion of controls shows that the TRAM is a suitable and effective measure to prevent falls from road tankers.
- The fall from height is controlled and so the consequence of fall from height is eliminated.
- The exposure or rate of access to the top of road tankers may not change but the risk of fall has been controlled which mitigates the effect of exposure on the total risk.
- Total residual risk is acceptable.

4. Discussion

The Law

The transport industry is concerned by the issue of height safety, but in controlling the risk of falls from road tankers there is also a concern from the fleet operators of the need for regulatory compliance.

The NSW Occupational Health and Safety Regulation 2001 sets out how falls are to be controlled when working at height. The following discussion will look at controls, as required by the Regulation, with examples from height safety in road tankers.

Occupational Health and Safety Regulation 2001

Part 4.3 Use of places of work

Division 6 Working at heights

Clause 56 Prevention of falls from heights – particular risk control measures

(1) *An employer must ensure that the risks associated with falls from height are controlled by the use of the following measures:*

a. *Provision and maintenance of:*

i. *A stable securely fenced work platform (such as scaffolding or other form of portable work platform)*

Fixed gantries are an example of the control described in this provision of the Regulation. As described in the Risk Assessment, loading and unloading at locations with fixed gantries is a suitable and effective control to the risk of falls from road tankers.

ii. *If compliance with subparagraph (i) is not reasonably practicable – secure perimeter screens, fencing, handrails or other forms of physical barriers that are capable of preventing a fall of a person*

It is not reasonably practicable to limit access to the top of road tankers to locations with fixed gantries, so other controls will be required. This provision of the regulation describes controlling the risk of falls with a 'secure perimeter...handrails...or... physical barriers that are capable of preventing the fall of a person'.

It may be intuitive to consider the inclusion of 'pop up' handrails as an example of this control measure, but the qualifying terms 'secure perimeter' may exclude them as a control as defined by this part of the regulation. As described in the Risk Assessment, handrails on road tankers usually provide a barrier along only one edge and do not provide a 'secure perimeter'. Handrail systems do not provide a 'secure perimeter' or a 'physical barrier capable of preventing a fall' at the point of access and egress to the top of the road tanker – the top of the ladder.

The defining terms of the regulation prescribe what is required as a physical barrier to control the risk of falls from height. This definition excludes 'pop up' handrails as a control and shows how 'pop up' handrails are not *an effective physical barrier*.



- iii. *If compliance with subparagraph (ii) is not reasonably practicable – other forms of physical restraints that are capable of arresting the fall of a person from a height of more than 2 metres*

The use of fall restraint and fall arrest is described in this part of the Regulation.

The TRAM is a 'total restraint' control as described in Australian/New Zealand Standard 1891 Industrial fall-arrest systems and devices Part 4: Selection, use and maintenance. The Standard defines that total restraint will prevent a person from reaching a position where there is a risk of fall. Total restraint provides a greater level of safety when working at heights than the use of fall arrest systems.

The terms of this part the regulation clearly include the use of the TRAM as a control for working at heights on top of road tankers.

- b. Provision of a safe means of movement between different levels at the place of work*

The Regulation requires that risk of fall must be controlled whilst moving between different levels of work, such as climbing the ladder on to the tanker. This Risk Assessment has shown that the TRAM is the only system that controls the risk of fall when moving from the ladder to on top of the tanker and back off the tanker on to the top of the ladder.

The TRAM is the only control that satisfies the requirements of this part of the provision when accessing the top of road tankers from their ladder.

Risk and Controls

The assessment of risk has shown that the risk of falling from road tankers is very high and must be controlled with suitable and effective measures.

The risk of falling from road tankers cannot be eliminated; therefore other controls must be used to mitigate the risk.

The TRAM utilises innovative engineering to provide a fall protection system that is specifically designed for road tankers.

The TRAM controls the risk of fall from road tankers.

The TRAM was assessed to be a more effective measure than handrails and static line systems in preventing falls from road tankers. Handrails and static line systems do not adequately control the risk of falling from road tankers, as the risk of moving on to the tanker from the ladder, and off the top of the tanker back on to the ladder is not controlled. Many of case studies in the *Falls from Road Tanker Fall Event Histories* (see Appendix I) show that there is a risk of falling at this transition. The TRAM is the only safety system that controls the risk of falling when moving on to the top of the tanker from the ladder, and off the top of the tanker back on to the ladder, as well as movement along the top of the tanker.

5. Conclusion

The TRAM was found to comply with the requirements of the NSW Occupational Health and Safety Regulation 2001.

The Risk Assessment found that the TRAM is a suitable and effective measure to prevent falls from road tankers.

References

- AS/NZS4360 Risk Management
- Fine (1971) Journal of Safety Research 3,157
- NOHSC (2000) Work-related fatalities involving falls in Australia, 1989-1992
- NSW Occupational Health and Safety Act 2000
- NSW Occupational Health and Safety Regulation 2001
- US Department of Health and Human Services (2000) Worker Deaths by Falls A Summary of Surveillance Findings and Investigative Case Reports
- WorkCover NSW Health and Safety Code of Practice for Risk Assessment
- WorkCover NSW Health and Safety Guide: Risk Management at Work

Appendix I: Falls From Road Tankers Fall Event Histories